

**MODERN METHODOLOGICAL MEANS OF TEACHING GRAPHIC DISCIPLINES  
FOR FIRST-YEAR STUDENTS****Brednyova V.P.**PhD (Candidate of Technical Sciences), Professor of Department  
of Descriptive Geometry and Engineer Graphic  
vera2008@ukr.net, ORCID 0000-0002-3005-2384*Architectural and Art Institute,  
Odessa State Academy of Civil Engineering and Architecture*

**Abstract.** In today's complex social conditions, significant changes are taking place in the system of domestic higher education. High-quality graphic training of graduates of higher educational institutions has been a pressing problem for many decades, so it is necessary to systematically update the existing methodological base and develop effective forms of training. As you know, drawing is the international language of architects and engineers. Working with flat images of spatial objects requires students to have developed spatial thinking already in the first year. In this study, detailed attention is paid to the review and analysis of existing methodological approaches to the teaching of important classical sections of the discipline "Descriptive Geometry". The trends of improving teaching under the condition of distance learning are also considered, which helps future specialists of creative specialties to increase the level of individual competitiveness in modern market conditions. The purpose of the research is to determine and improve modern methodological tools for teaching graphic disciplines of students of the first course of creative specialties. Our study is related to the scientific research work "Improving the organization of the educational process using distance learning methods and teaching methods of graphic disciplines for students of construction and architectural and art specialties based on the competence approach", which is carried out on the basis of the Department of "Descriptive Geometry and Engineering Graphics" Odessa State Academy of Construction and Architecture (OSACEA) for many recent years. The work uses theoretical and empirical research methods: analysis, classification and synthesis of research base sources, many years of personal teaching experience; diagnostics of students specializing in 191 Architecture and Urban Planning and 023 Fine Arts (observations, monitoring the quality of teaching, self-analysis, etc.). Graphic competencies are very significant for a graduate's future professional activity, which gives freedom in the creative implementation of the entire design process from the birth of an idea to its implementation.

**Keywords:** graphic disciplines, Descriptive geometry, methodological means, first-year students.

**Introduction.** Descriptive geometry is one of the first academic disciplines with which graphic technical education of architects, artists, designers, and engineers should begin. The main objectives of this science are to study theoretical methods for graphically constructing three-dimensional spatial objects on a plane, acquiring practical skills in constructing images (orthogonal, axonometric, perspective, etc.) and graphical methods for solving various applied problems. Difficulties in mastering it may be associated with the special dependence of spatial imagination on logical thinking - without the formation of such an opportunity, it is quite difficult to feel freedom in creativity. To draw an object, you need to professionally know and follow certain rules for constructing an image, imagine the shape of a spatial object, and understand the meaning of graphic operations performed in a certain sequence.

**Formulation of the task.** The model of the educational process for the near future is one of the areas of improvement of the entire education system, which contributes to the wide introduction of modern methodological and methodical principles of education into the educational process. The main concept of the purpose of the conducted research is based on the comparative results of the analytical review of methodological, methodical and practical aspects of graphic education.

**Analysis of the latest sources of research and publications.** The state of graphic training in higher educational institutions is widely discussed in the studies of modern scientists and geometers [1, 44-48; 2; 5, 642-644; 6, 101-104; 7, 38-42 та ін.]. Of particular interest are works that discuss the issue of the effective application of methodological developments from the point of view of the content and scope of educational tasks [3; 4; 9, 149-153; 10, 31-45; 13 та ін.]. The problems of the subjects of tasks remain not fully resolved - separately according to specialties [8, 152-160; 11, 116-121; 12 та ін.].

**The basic material and results.** In connection with the increase in European and global requirements for the quality and level of training of graduates of higher education, individual graphic competencies contribute to a more widespread choice of future functional capabilities of the acquirer, because professional competencies are objectively necessary knowledge and skills required by the future practical activity of an architect, artist or engineer. The author's more than thirty years of teaching experience in graphic disciplines allows us to say that the individual technical knowledge and skills of students of creative specialties are one of the most important components of professional competence and presuppose the possession of the required amount of special subject skills, the ability to effectively apply them in solving educational and creative tasks. In our opinion, it is very important to provide a significant and solid stock of knowledge in descriptive geometry, which is necessary for professional activity. As examples of the importance of studying descriptive geometry, consider the works of the classical course of the discipline, where it is necessary to know and competently apply the basic methods of orthogonal design, solving positional and metric problems, constructing axonometric and perspective images of spatial objects, etc. In addition, it is very important to know the classification of surfaces, because understanding the shape of an object is based on its distribution into components. Thus, to perform any task, one cannot do without knowledge of elementary definitions, concepts, and skills provided by sketch geometry

Our research is based on the comparative volume of graphic control works at the department of sketch geometry and engineering graphics of OSACEA students of architectural and artistic specialties in the first semester using traditional and innovative approaches. On fig. 1-4 are examples of student graphic control works on the following topics:

Fig. 1: Task and construction of the surface of the polyhedron on the complex drawing. Fig. 2: mutual intersection of two polyhedral surfaces and two surfaces of rotation. Fig. 3: Solving metric problems. Transformation of a complex drawing. Fig. 4.: Projections with numerical marks. Fig. 5: Construction of a perspective image of a group of schematic buildings. Fig. 6.: Construction of axonometric images of a group of schematic buildings.

Fig. 7 shows the construction of an axonometric image of spatial forms (for art students).

For several years, our Academy has been teaching subjects in English, which is a strong motivating factor for students. As a rule, classroom classes are conducted in a bilingual form, that is, the provision of educational material is mixed - in Ukrainian and English. To carry out the educational process and conduct classes in graphic disciplines, the department has created an educational and methodological complex, which includes lecture notes (in Ukrainian and English), a study guide, a workshop, methodological recommendations, etc.

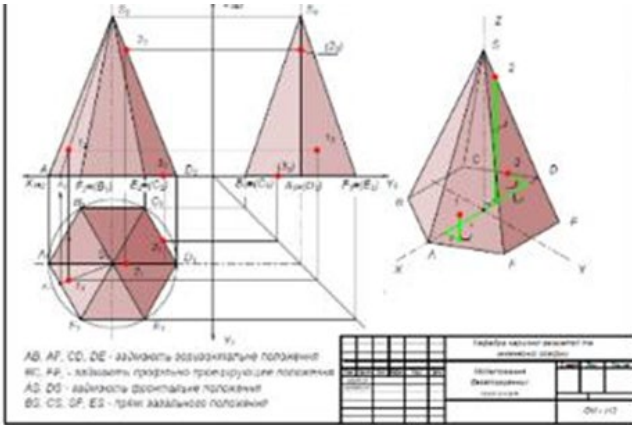

**Fig. 1:** Task and construction of the surface of the polyhedron on the complex drawing

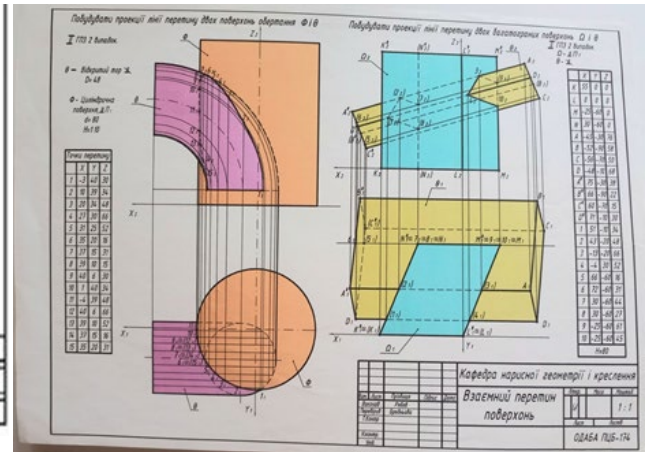

**Fig. 2.** Mutual intersection of two polyhedral surfaces and two surfaces of rotation

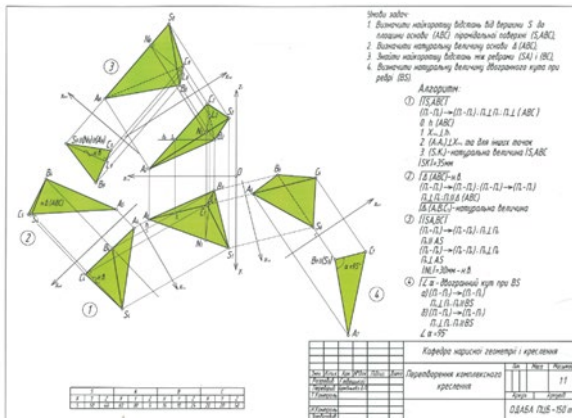

**Fig. 3:** Solving metric problems. Transformation of a complex drawing.

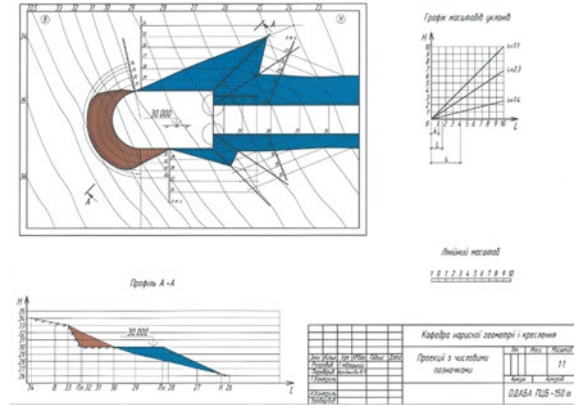

**Fig. 4.:** Projections with numerical marks

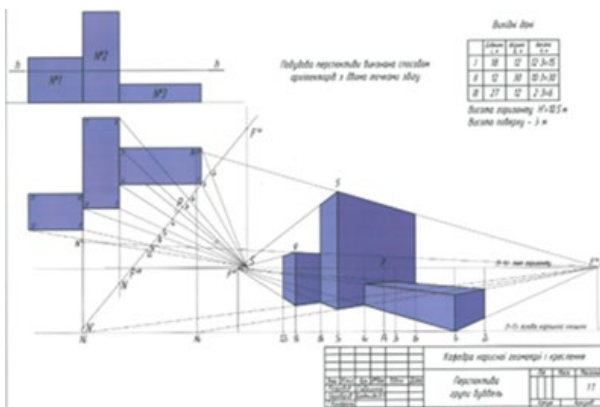

**Fig. 5:** Construction of a perspective image of a group of schematic buildings.

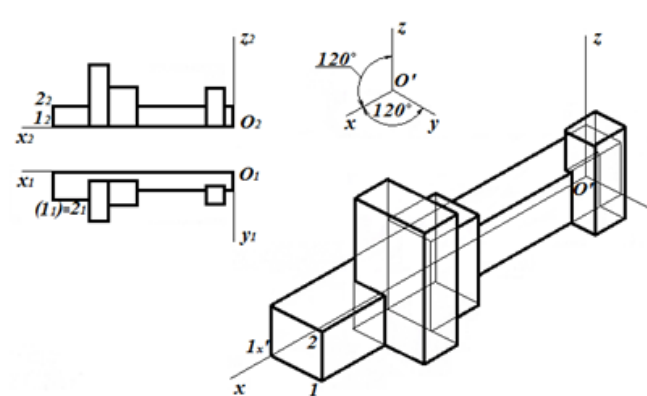

**Fig. 6.:** Construction of axonometric images of a group of schematic buildings

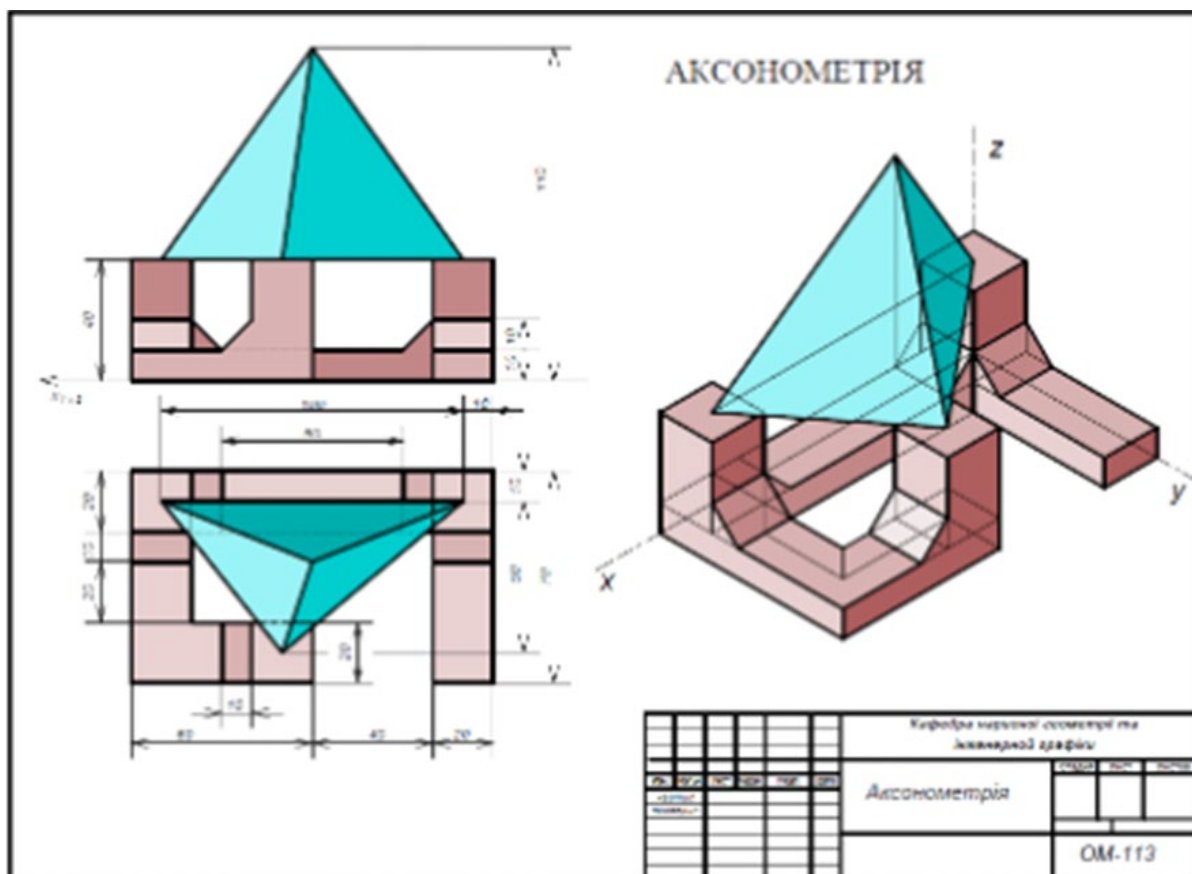

**Fig.7.** The construction of an axonometric image of spatial forms (for art students)

Conclusions and prospects for further research. Both traditional (lectures, practical classes, consultations, etc.) and innovative (development of blocks and test tasks on separate topics, formulation of target graphic tasks, formation of algorithms for solving problems of different levels of complexity and step-by-step monitoring) are important for improving quality, taking into account individual characteristics in the training of students, etc.). In this regard, the formation of students' motivation and interest during the entire educational process, awareness of the need to obtain high-quality graphic education, which is a guarantee of success in future professional activities, is of urgent and important importance. Let's emphasize the need to increase the efficiency of not only classroom contact time, but also outside classroom work. This requires teachers to constantly search for new ways and approaches that should contribute to high-quality assimilation of educational material. The system of evaluating the level of educational achievements is based on the principles of ECTS. Summarizing the results of the conducted research emphasizes the fact that achieving a high level of graphic training quality also depends on the effectiveness of the methodological and methodical implementation of the discipline and on the professionalism of a specific teacher.

Distance learning for the system of higher education is an innovation that requires significant efforts for its practical implementation from both the students' and the teacher's side, so it was necessary to change and modernize the teaching methods of graphic disciplines in the shortest possible time. Studying the experience of teaching graphic disciplines by different teachers, we emphasize that each of them has his own view on the methodology and methodology of using certain didactic tools and forms of control, therefore, from our point of view, to increase the effectiveness of the educational process and achieve its best results, a compatible the work of various teachers.

In our opinion, further research in this direction will help the development of modern methodological and methodical approaches to the process of teaching graphic disciplines.

## References

- [1] Конюк А.Є. Историчний досвід архітектурно-планувальної організації енергоекономічної та екологічної житлової забудови. Наук.-техн. Зб. Сучасні проблеми архітектури та містобудування. Київ: КНУБА. 2016. Вип. № 43 (2). С. 107–113
- [1]. Drach I.I. (2008). Kompetentnisnyi pidkhid yak zasib modernizatsii zmistu vyshchoi osvity [Competence approach as the way of modernizing the content of higher education]. Problemy osvity Problems of education.vip.57. P. 44-48 [in Ukrainian].
- [2]. Kompetentnisnyi pidkhid u suchasni osviti (2004): svitovyi dosvid ta ukraïnski perspektivy [Competence approach in modern education: world experience and Ukrainian prospects]. O.V.Ovcharuk, Kyiv: Biblioteka z osvithoi polityky. P.112 [in Ukrainian].
- [3]. Brednyova V.P., Dzuguryan T.G., Marchenko V.S. (2009) Engineering graphics. Brief lecture note on descriptive geometry for first-year students of construction specialties. Odesa: Astroprint. 204 p. [in Russian]
- [4]. Brednyova V.P. (2013). Descriptive geometry. Constructive and applied problems with theory elements. Study guide for higher technical schools. education closing Odesa: Astroprint. P.196 [in Ukrainian].
- [5]. Brednyova V.P.(2007). Pro neobhidnist jakisnoyi profesionalnoyi hudozhnyo-grafichnoyi pidgotovki maibutnikh arhitektoriv. Sbornik nauchnikh trudov. Regionalniye problemi arhitekturi i gradostroitelstva. №9-10, p. 642-644 [in Ukrainian].
- [6]. Brednyova V.P., Prohorets I.M., Mihaylenko E.V. (2021). Research on the methodology of teaching graphic disciplines with the purpose of developing the creative potential of higher education students. International scientific and practical conf. Pedagogy and Psychology in the Modern World. Wloclawek, Republic of Poland, vol.2, p.101-104 [in English].
- [7]. Bredniova V. (2016). On the improvement of the methodology of engineer staff's graphic training on the basis of optimization of psychological and pedagogical approaches. Modern Tendencies in Pedagogical Education and Science of Ukraine and Israel: The Way to Integration. Ariel University. №7. P. 38–42 [in English].
- [8]. Brednyova V.P., Yavorska N.M., Yavorskyi P.V. (2021). Classic problems of sketch geometry and their application in architectural and artistic practice. Sat. scientific works. Regional problems of architecture and urban planning. Odesa: №.15. С. 152-160 [in Ukrainian].
- [9]. Brednyova, Yavorska I.M., Yavorskyi E.V., Smichkovska O.M. (2022). Ways to improve the graphic skills of future specialists in creative specialties. Journal of scientific works "Innovative pedagogy" - Black Sea Research Institute of Economics and Innovation. Collection. No. 48. Vol.1 P.149-153 [in Ukrainian].
- [10]. Kashekova I.E., Temirov T.V. (2013). Conceptual foundations of humanitarian education based on the cultural approach. / Humanitarian space. International almanac. Vol. 2, No. 1. Almanac. P. 31-45 [in Russian].
- [11]. Perperi A.O., Brednyova V.P., Perperi A.M. (2022). Research of the factors of increasing the quality of graphic competences of students of the first course of architectural and construction specialties. Problems of theory and history of architecture in Ukraine. Odesa:OSACEA. №22. С.116-121 [in English].
- [12]. Brednyova V.P. (2022).Graphic education is an important component of the artist's creative professionalism in architectural and artistic practice. Sat. scientific works. Regional problems of architecture and urban planning. Odesa: №.16. С. 227-233 [in Ukrainian].
- [13]. Mikhaïlenko V.I., Naidish V.M., Pidkoritov A.M., Skidan I.A.(2004). Engineering and computer graphics. Kiev: Vishcha School. 362 p. [in Ukrainian].
- [14]. Heller S. (2005). The education of a graphic designer. Allworth Press. P.369 [in English].

## Література

- [1.] Драч І.І. Компетентнісний підхід як засіб модернізації змісту вищої освіти - К.: Інститут інновац. технологій і змісту освіти МОН України.2008. Вип.57. С.44-48
- [2.] Компетентнісний підхід у сучасній освіті: світовий досвід та українські перспективи. Бібліотека з освітньої політики/Під заг. ред. О.В.Овчарук. К.: 2004.112 с.
- [3.] Бреднева В.П., Джугурян Т.Г., Марченко В.С. Инженерная графика. Краткий конспект лекций по начертательной геометрии для студентов первого курса строительных специальностей. Одесса: Астропринт, 2009. 204 с.
- [4.] Бредньова В.П. Нарисна геометрія. Конструктивні та прикладні задачі з елементами теорії. Навч.посібн.для вищ.техніч. навч. закл. Одеса: Астропринт. 2013. 196с.
- [5.] Бредньова В.П. Про необхідність якісної професійної художньо-графічної підготовки майбутніх архітекторів. – Сб.научных трудов. Региональные проблемы архитектуры и градостроительства. Одеса: 2007. №9-10. С. 642-644.
- [6.] Бредньова В.П., Прохорец І.М., Михайленко Е.В Research on the methodology of teaching graphic disciplines with the purpose of developing the creative potential of higher education students. International scientific and practical conf. Pedagogy and Psychology in the Modern World. Wloclawek, Republic of Poland, 2021, vol.2, p.101-104.
- [7.] Bredniova V. On the improvement of the methodology of engineer staff's graphic training on the basis of optimization of psychological and pedagogical approaches. Modern Tendencies in Pedagogical Education and Science of Ukraine and Israel: The Way to Integration. Ariel University.2016. №7. P. 38–42.
- [8.] Бредньова В.П., Яворська Н.М., Яворський П.В. Класичні задачі нарисної геометрії та їх застосування в архітектурно-художній практиці. Сб. научных трудов. Региональные проблемы архитектуры и градостроительства. Одеса: 2021. №15. С. 152-160.
- [9.] Бредньова, Яворська І.М., Яворський Е.В., Смичковська О.М. Шляхи удосконалення графічної майстерності майбутніх фахівців творчих спеціальностей. Журнал наукових праць «Інноваційна педагогіка» - Причорноморського науково-дослідного інституту економіки та інновацій.- Збірн. № 48, т 1, 2022. С. 149-153.
- [10.] Кашекова И.Э., Темиров Т.В. Концептуальные основы гуманитаризации образования на основе культурологического подхода. / Гуманитарное пространство. Международный альманах. 2013. Т. 2, №1. Альманах. С.31-45.
- [11.] Perperi A.O., Brednyova V.P., Perperi A.M. Research of the factors of increasing the quality of graphic competences of students of the first course of architectural and construction specialties Проблеми теорії та історії архітектури України, Одеса: ОДАБА.2022. №22. С.116-121.
- [12.] Бредньова В.П. Графічна освіта – важлива складова творчого професіоналізму митця в архітектурно-художній практиці. Сб. научных трудов. Региональные проблемы архитектуры и градостроительства. Одеса: 2022. №16. С. 227-233.
- [13.] Михайленко В.Є., Найдис В.М., Підкоритов А.М., Скидан І.А. Інженерна та комп'ютерна графіка. Київ: Вища школа, 2004. 362 с.
- [14.] Heller S. The education of a graphic designer. Allworth Press. 2005. 369 p.

## СУЧАСНІ МЕТОДОГІЧНІ ЗАСОБИ ВИКЛАДАННЯ ГРАФІЧНИХ ДИСЦИПЛІН СТУДЕНТАМ-ПЕРШОКУРСНИКАМ

**Бредньова В. П.,**

к. т. н., доц., професор кафедри Нарисної геометрії та інженерної графіки,  
vera2008@ukr.net, ORCID: 0000-0002-3005-2384

*Архітектурно-художній інститут,  
Одеська державна академія будівництва та архітектури*

**Анотація.** У сучасних складних соціальних умовах у системі вітчизняної вищої освіти відбуваються суттєві зміни. Якісна графічна підготовка випускників вищих навчальних закладів є актуальною проблемою протягом багатьох десятиліть, тому потрібне систематичне оновлення існуючої методичної бази та розробка ефективних форм навчання. Як відомо, креслення – міжнародна мова архітекторів та інженерів. Робота з плоскими зображеннями просторових об'єктів вимагає від учнів розвиненого просторового мислення вже на першому курсі. У цьому дослідженні детальну увагу приділено огляду та аналізу існуючих методологічних підходів до викладання важливих класичних розділів дисципліни «Нарисна геометрія». Також розглядаються тенденції удосконалення викладання за умовою дистанційного навчання, що сприяє майбутнім фахівцям творчих спеціальностей підвищити рівень індивідуальної конкурентоспроможності у сучасних ринкових умовах. У роботі використано теоретичні та емпіричні методи дослідження: аналіз, класифікація та синтез джерел дослідницької бази, багаторічний особистий педагогічний досвід; діагностика студентів спеціальностей 191 «Архітектура та містобудування» та 023 «Образотворче мистецтво» (спостереження, контроль якості викладання, самоаналіз тощо). Графічні компетенції мають значення для майбутньої професійної діяльності випускника, що дає свободу у творчій реалізації всього процесу проектування від зародження ідеї до її реалізації.

**Ключові слова:** графічні дисципліни, Нарисна геометрія, методологічні засоби, студенти-першокурсники.